



8 4 expo

acht | eight | восемь | huit | otto | ocho | 八



Table of Content

[2](#) [VORWORT / PREFACE](#)

[4](#) [Vorteile / Advantages](#)

[6](#) [Projekte / Projects](#)

[56](#) [Marken / Trade Marks](#)

[59](#) [Designpreise / Design Awards](#)

acht | eight | восемь | huit | otto | ocho | 八

Vorwort

„8“ – das innovative Architektursystem für den Ausstellungs- und Messebau

„8“ ist die neue Lösung für die Architekturgestaltung in der Welt der Raumkommunikation. Wir können anhand zahlreicher Projekte unterschiedlicher Größe zeigen, dass „8“ sich hervorragend als ein leistungsfähiges und technisch besonders vielseitiges Architektursystem eignet. Es erfüllt alle wichtigen Anforderungen an ein smartes und modernes Design.

Die 8 (acht / eight / otto ...) umseitig integrierten Multi-Funktionsnuten, die über Eck in das Vierkantprofil eingebracht sind, verleihen dem System nicht nur seine unverwechselbare, reduzierte Ästhetik, sondern sie dienen zudem einer einzigartigen Funktionalität. Eine nahtlose Aufnahme von Wanddesigns und Werkstoffen erfolgt in diesen 8 Nuten. Vornehmlich an den Wandscheiben werden textile, individuell gestaltbare Spanntücher mittels eines Keders einfach in die Nuten gesteckt und gespannt. Sie sind damit schnell auszutauschen, mühelos zu verpacken, sowie leicht zu transportieren und zu lagern.

Das vielseitige, smarte Zubehör gewährleistet stets sichere und montagefreundliche Applikationen an der Raumstatik. Ein geringes Gewicht bei höchster Stabilität erlaubt immer neue und anspruchsvolle Konstruktionen. 84expo bietet somit jede Menge Raum für kreative Ideen.

Die zunehmenden Anforderungen an die Nachhaltigkeit bezieht das Raumsystem vor allem aus der Zielsetzung seiner Entwickler, mit nur einem Aluminiumprofil für die gesamte Raumstruktur auszukommen. Dies spart jede Menge Energie und Kosten für die Umwelt im gesamten Produktionsprozess von Bauten, bei gleichzeitig höchstem Anspruch an die Vielfalt von Gestaltungsoptionen.

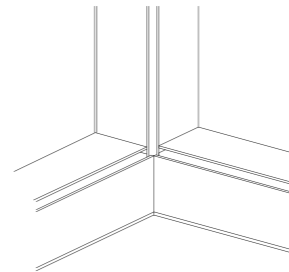
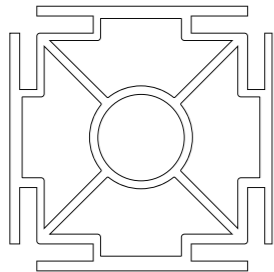

Preface

“8” – the innovative architectural system for exhibition and trade fair construction

“8” is the new solution for architectural design in the world of spatial communication. We can demonstrate from numerous projects of different sizes that “8” is outstanding as a powerful and technically particularly versatile architectural system. It meets all the important requirements for smart and modern design.

The 8 (acht / eight / otto ...) multi-functional grooves integrated into the square profile on the reverse side not only give the system its unmistakable, reduced aesthetics, but they also serve a unique functionality. Seamless accommodation of wall designs and materials takes place in these 8 grooves. Primarily on the wall panels, textile, individually designable tensioning cloths are simply inserted and tensioned into the grooves by means of a keder. This makes them child’s play to replace, effortless to pack, and easy to transport and store.

The versatile, smart accessories always ensure safe and installation-friendly applications to the room statics. A low weight at highest stability allows always new and sophisticated constructions. “84expo” thus offers plenty of room for creative ideas.

The room system’s increasing sustainability requirements are primarily due to its developers’ objective of using only one aluminum profile for the entire room structure. This saves a lot of energy and costs for the environment in the entire production process of buildings, while at the same time providing the highest demand on the variety of design possibilities.

Karlsruhe, the 10th February 2024

Christof Zimmermann
Owner ICON GmbH



Ästhetik und Funktion / Aesthetics and function

Das Profil „8“ vereint filigrane Ästhetik mit maximaler Funktion – in der Seitenansicht wirkt es sehr reduziert, wie ein Vierkantrohr mit je einer Schattenfuge an den Kanten. Im Querschnitt erkennt man, dass das Profil über Eck angeordnete Funktionsnuten hat, die zur spaltfreien Befestigung von Stoffbannern mit Kederprofil genutzt werden. Ebenso kann man Plattenwerkstoffe und Zubehörteile daran befestigen.

The “8” profile unites delicate aesthetics with maximum function: appearing very basic – a rectangular bar with a shadow gap to each edge. In the cross-sectional view you can see grooves around the edge of the profile that allow seamless fitting of canvases with keder hems, as well as the mounting of panel materials or accessories.

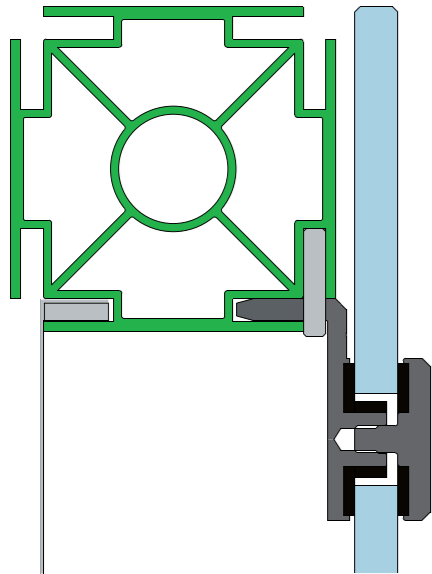

Nachhaltigkeit / Sustainability

Das System „84expo“ hilft dabei, mit minimalem Aufwand an Material und Bauteilen sehr schnell zum Ziel zu kommen, weil das Aluminiumprofil mit integriertem Knoten aus Edelstahl-Feinguß trotz des geringen Querschnitts enorm stabil ist. Die Reduktion und formale Klarheit, sowie der Einsatz hochwertiger Materialien gewährleisten Langlebigkeit, Nachhaltigkeit und Ressourcenschonung.

The system “84expo” helps to achieve the goal very quickly with a minimum of material and components, because the aluminum profile with integrated node made of stainless steel investment casting is enormously stable despite the small cross-section. The reduction and formal clarity as well as the use of high-quality materials ensure durability, sustainability and resource conservation.

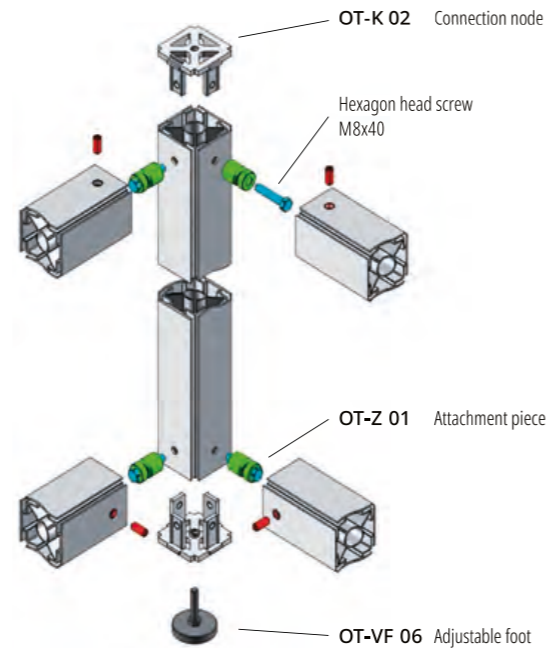

Ergänzungen / Additional features

In den 8 (acht/eight/otto ...) Nuten können Ergänzungselemente wie Projektionssegel, Beamer, Monitore, Whiteboards, Bilderabhängungen, Beleuchtung oder Regalablagen problemlos montiert werden.

Additional elements such as projection sails, beamers, monitors, whiteboards, image hangers, lighting or shelf supports can be easily mounted in the 8 (acht/eight/otto ...) grooves.



8 4 expo



Project Trade fair stand – “R+T”, World’s Leading Trade Fair for Roller Shutters, Doors and Sun Protection, Stuttgart
Client Ziptrak Pty Ltd., Australia
Design ICON GmbH – Ziptrak Pty Ltd.



Project Exhibition stand – “EMO”, World’s Leading Trade Fair for Machine Tools and Metalworking, Hanover, Germany
Client NILES-SIMMONS-HEGENSCHEIDT GmbH - NSH GROUP
Design ICON GmbH

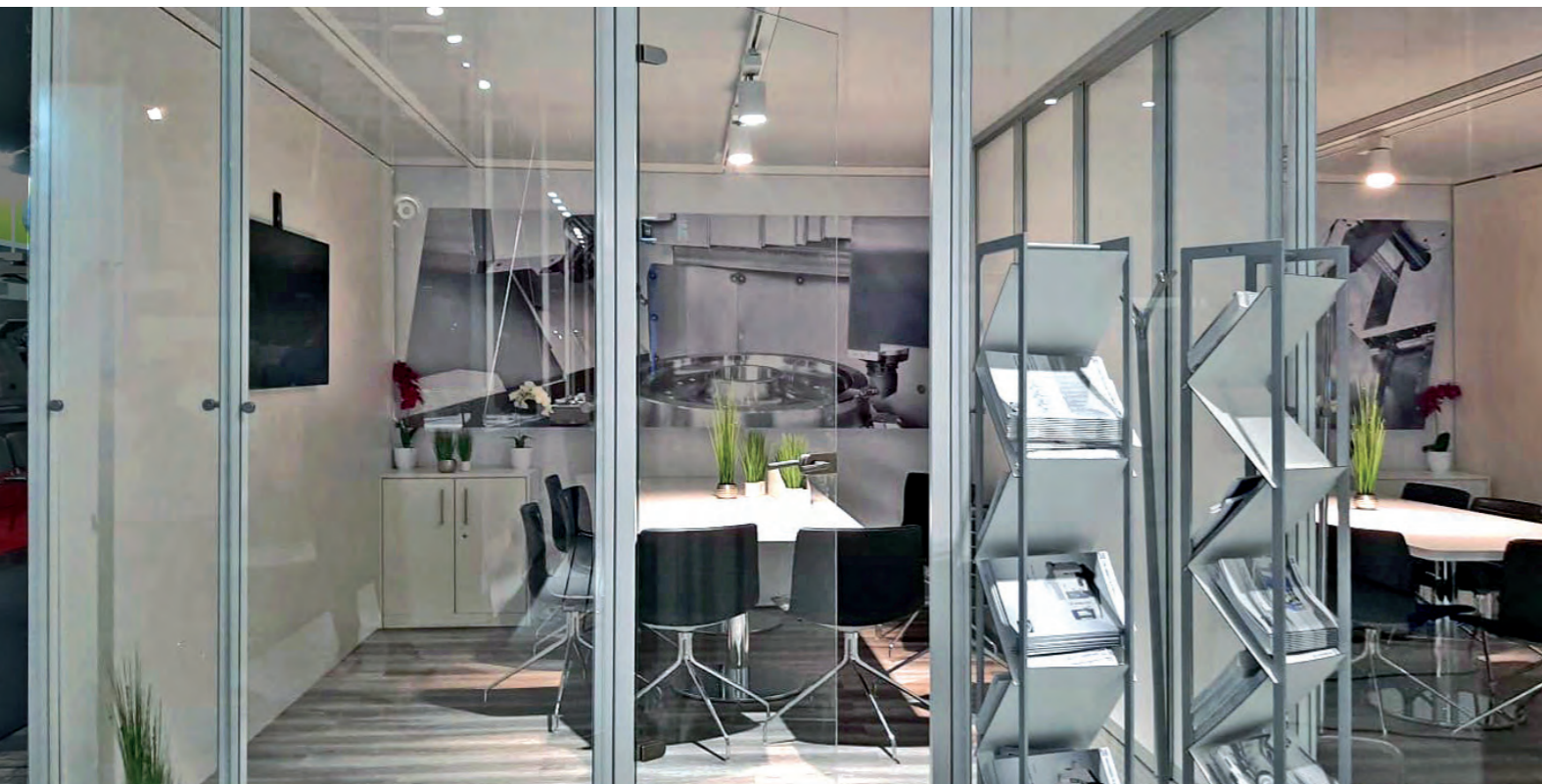

Project Exhibition stand – “EMO”, World’s Leading Trade Fair for Machine Tools and Metalworking, Hanover, Germany
Client NILES-SIMMONS-HEGENSCHEIDT GmbH - NSH GROUP
Design ICON GmbH



Project Exhibition stand – “EMO”, World’s Leading Trade Fair for Machine Tools and Metalworking, Hanover, Germany
Client Werkzeugmaschinenfabrik (WEMA) Glauchau GmbH - NSH GROUP
Design ICON GmbH



Project Exhibition stand – “42nd Morphology-Histology Days”, Wiesloch, Germany
Client A. MENARINI Diagnostics Deutschland
Design ICON GmbH – tac office marketing e.K.



Project Trade fair stand – “SEMICON Europa”, Munich, Germany
Client RENA Technologies GmbH
Design ICON GmbH – RENA Technologies GmbH

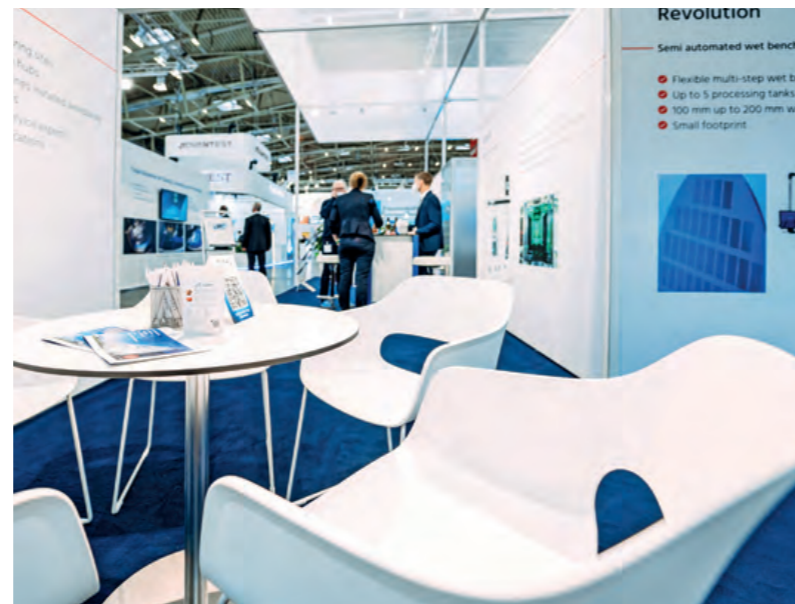

8₄ office TUTTI-FRUTTI

Winner of the German Design Award 2022
- Excellent Product Design - Office Furniture

Project Trade fair stand – “SEMICON Europa”, Munich, Germany
Client RENA Technologies GmbH
Design ICON GmbH – RENA Technologies GmbH



Project Exhibition stand – “IFAT”, Munich, Germany
Client BELLMER GmbH
Design ICON GmbH – BELLMER GmbH



Project Exhibition stands – “The Hall Of Vape”, Vape Expo, Stuttgart, Germany
Client Velvet Vape - Daddy's Vapor - Revoltage
Design ICON GmbH – Velvet Vape / WB STUDIO LLC / KLS Vertrieb GmbH



Project Exhibition stand – “IZB”, International Suppliers Fair, Wolfsburg, Germany
Client Kale Bağlantı Teknolojileri San. ve Tic. A.Ş., Türkiye
Design ICON GmbH – Kale Bağlantı Teknolojileri San. ve Tic. A.Ş.

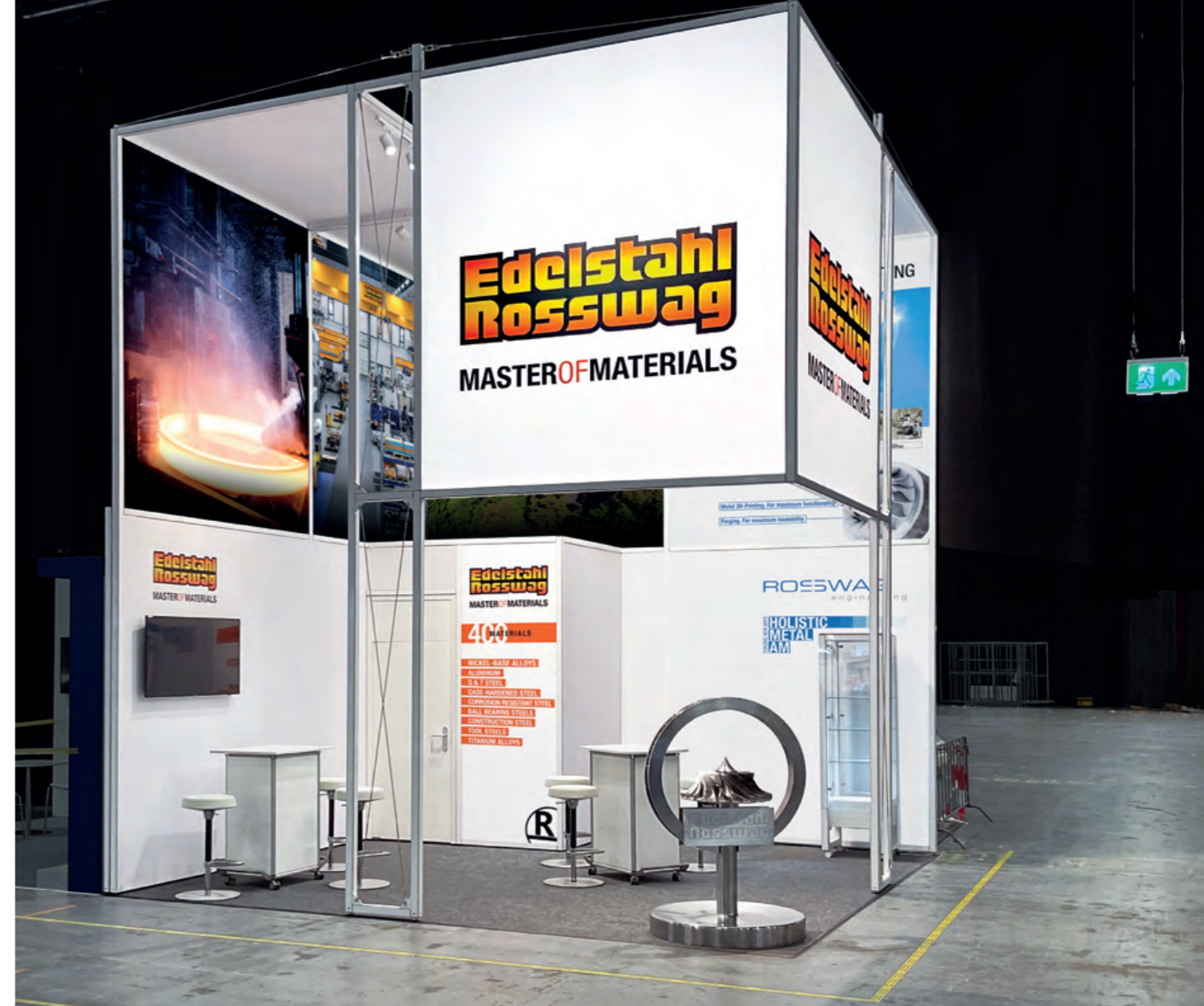

Project Trade Fair Stand – “SSW”, Stainless Steel World, Maastricht, Netherlands
Client Rosswag GmbH
Design ICON GmbH – Rosswag GmbH



8₄ office TUTTI-FRUTTI

Winner of the German Design Award 2022
- Excellent Product Design - Office Furniture

Project Exhibition stand – “ORGATEC”, Cologne, Germany
Client ICON GmbH featuring HAMERWÖRK d-sign
Design ICON GmbH + Andrzej Staniszewski (Architect)

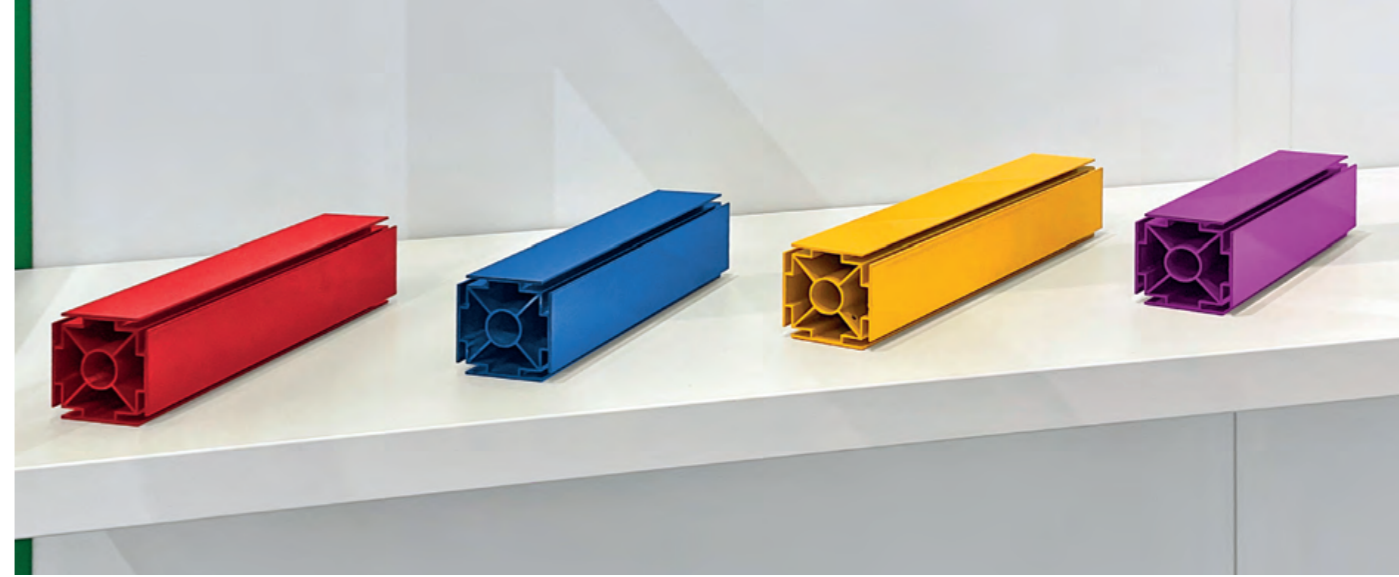

Project Exhibition stand – “ORGATEC”, Cologne, Germany
Client ICON GmbH featuring HAMERWÖRK d-sign
Design ICON GmbH + Andrzej Staniszewski (Architect)



Project Trade fair stand – “LogiMAT”, Stuttgart, Germany
Client ASPION GmbH
Design ICON GmbH – ASPION GmbH



Project Exhibition stand – “ESCRS Congress”, Milan, Italy
Client Mediphacos Industrias Medicas S/A, Brasil
Design ICON GmbH – Mediphacos Industrias Medicas S/A

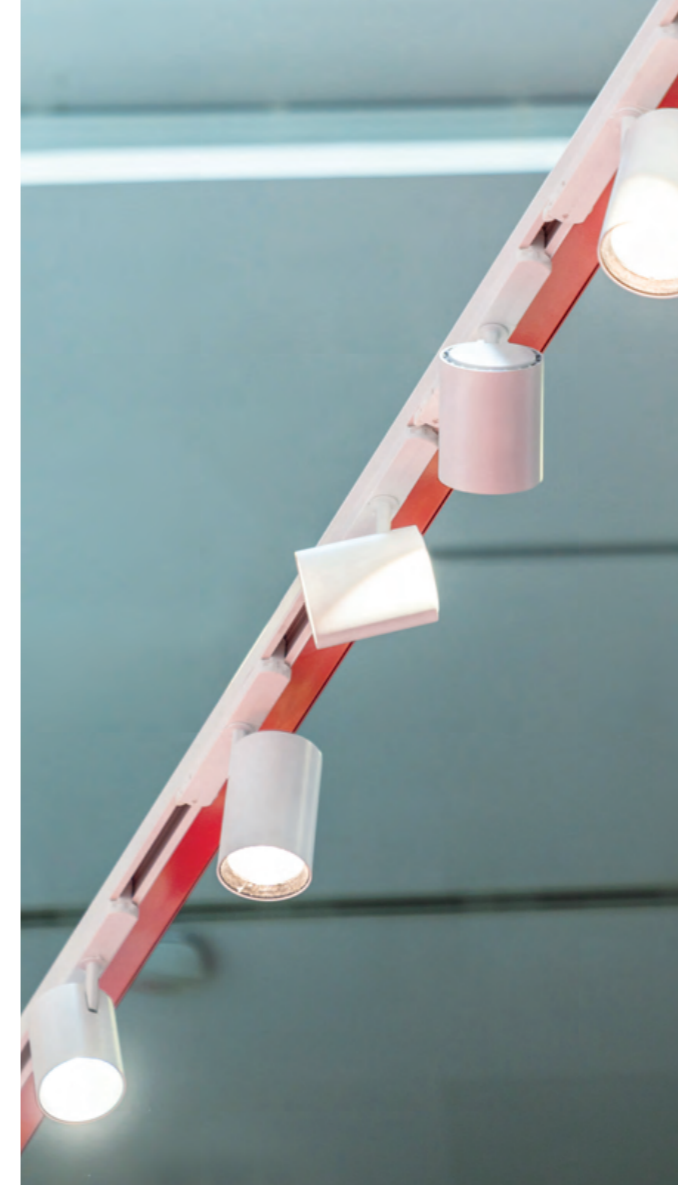

Project Exhibition stand – “Spielwarenmesse”, Nuremberg, Germany
Client DVSI – Deutscher Verband der Spielwarenindustrie e.V.
Design ICON GmbH – DVSI



Project Exhibition stand – “ambiente”, world’s most important consumer goods trade fair, Frankfurt, Germany
Client VINZERHOME Sp. z o.o., Poland
Design ICON GmbH – VINZERHOME Sp. z o.o.



Project Trade fair stand – “LogiMAT”, Stuttgart, Germany
Client ASPiON GmbH
Design ICON GmbH – ASPiON GmbH



Project Exhibition stand – “Fastener Fair”, Stuttgart, Germany
Client Kale Bağlantı Teknolojileri San. ve Tic. A.S., Türkiye
Design ICON GmbH – Kale Bağlantı Teknolojileri San. ve Tic. A.S.



Project Exhibition stand – “Euroshop”, Dusseldorf, Germany
Client ICON GmbH
Design ICON GmbH



Project Exhibition stand – “Space Tech Expo”, Bremen, Germany
Client Rhopoint Components Ltd, United Kingdom
Design ICON GmbH – Rhopoint Components Ltd



Project Exhibition stand – “BlechExpo”, Stuttgart, Germany
Client SCHEUERMANN + HEILIG GmbH
Design ICON GmbH – SCHEUERMANN + HEILIG GmbH



Project Trade fair stand – “Inhorgenta”, Munich, Germany
Client Herzog GmbH
Design ICON GmbH – Herzog GmbH



Project Trade fair stand – “R+T”, World’s Leading Trade Fair for Roller Shutters, Doors and Sun Protection, Stuttgart
Client Ziptrak Pty Ltd., Australia
Design ICON GmbH – Ziptrak Pty Ltd.



8₄ office

Interior + Workplace

8₄ fun

Leisure market + Outdoor

8₄ expo

Trade fair + Exhibition

8₄ signage

Advertising + Guiding

84 expo

acht | eight | восемь | huit | otto | ocho | 八



ICONIC AWARDS 2023
Innovative Architecture - selection

PROJEKTBESCHREIBUNG

84expo ist die neue Lösung für die Architekturgestaltung in der Welt der Raumkommunikation. Wir können anhand zahlreicher Projekte unterschiedlicher Größe zeigen, dass 84expo sich hervorragend als ein leistungsfähiges und technisch besonders vielseitiges Architektursystem eignet. Es erfüllt alle wichtigen Anforderungen an ein smartes und modernes Design. Seine besondere Nachhaltigkeit bezieht 84expo darauf, dass es mit nur einem Aluminiumprofil für die gesamte Raumstruktur auskommt.

PROJEKT DESCRIPTION

84expo is the new solution for architectural design in the world of spatial communication. We can show from numerous projects of different sizes that 84expo is excellently suited as a powerful and technically particularly versatile architectural system. It fulfils all the important requirements of smart and modern design. 84expo derives its special sustainability from the fact that it only needs one aluminium profile for the entire room structure.



GERMAN DESIGN AWARD 2024
Excellent Architecture - Fair and Exhibition

AWARD FÜR EXZELLENTES DESIGN

Der German Design Award ist der Premiumpreis des Rat für Formgebung. Mit seinem weltweiten Spektrum und seiner internationalen Strahlkraft zählt er branchenübergreifend zu den angesehensten Awards der Designlandschaft. Seit 2012 identifiziert der German Design Award maßgebliche Gestaltungstrends, präsentiert sie einer breiten Öffentlichkeit und zeichnet sie aus. So werden jährlich außerordentliche Einreichungen im Produktdesign, Kommunikationsdesign und der Architektur gekürt.

AWARD FOR EXCELLENT DESIGN

The German Design Awards are the premium prize of the German Design Council. With its global scope and international appeal, it is one of the most prestigious awards in the design landscape across all industries. Since 2012, the German Design Awards have been identifying key design trends, presenting them to a broad public and honouring them. Extraordinary submissions in product design, communications design and architecture are selected each year.



ICON GmbH ■ Kleinsteinbacher Straße 71 ■ 76228 Karlsruhe-Stupferich
Tel +49 (0) 721 9686 1910 ■ www.iconnet.de ■ www.84expo.de